



## 1-1/2"氣動閥 1-1/2" Pneumatic valve WLAL Series

### 作動說明 Specification

管徑大小 End connection	12 : 1-1/2"	
使用流體 Working liquid	純水或藥液 Pure water or chemical liquids (註1)	
使用溫度 Fluid temperature	5~35°C	
閥耐壓 Withstanding pressure	0.8 MPa(水壓 Under water pressure)	
流體壓力 Fluid pressure	單動操作 Single action	A→B B→A
閥背壓 Back Pressure	0~0.4 MPa	
閥洩漏 Valve seat leakage	0 (水壓)	
周圍溫度 Ambient temperature	0~35°C	
頻率 Frequency	4次/分鐘以下	
裝卸方式 Mounting orientation	任意	
CV值 Cv value	24	
Orifice	Ø 40	
操作端 Operation section	操作壓力 Operation pressure	0.3~0.6 MPa
	操作端 Operation connection	1/8" NPT (使用操作口NC:O端口)

### 內部架構圖 Internal structure and parts lists

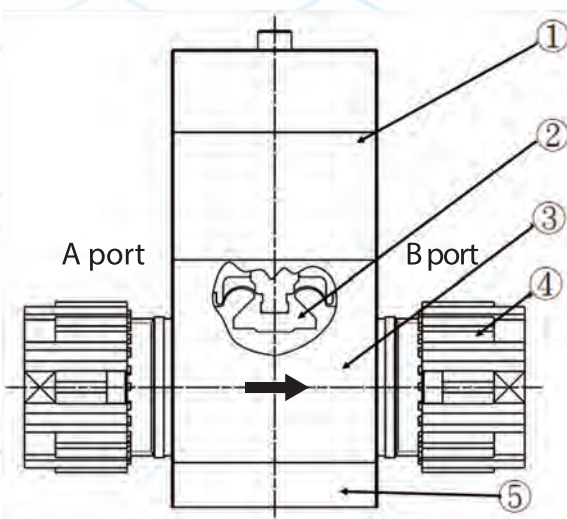

零件名稱 Part	材質 Material
① 驅動部 Actuator	PP
② 膜片 Diaphragm	PTFE
③ 本體 Body	PTFE
④ 螺帽 Nut	PFA
⑤ 底板 Base	PP

# WLAL -

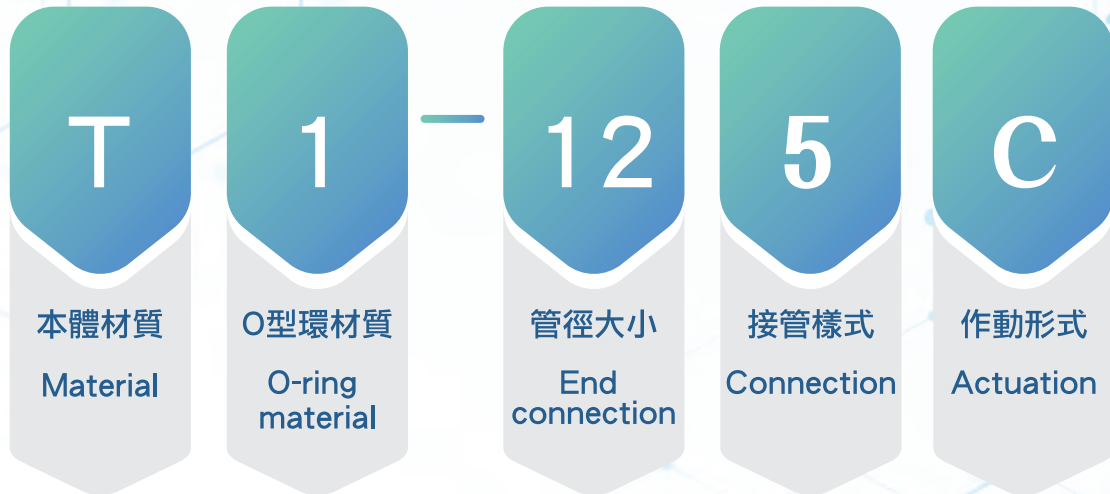

WL	種類 Type	本體材質 Material	O型環材質 O-ring material	管徑大小 End connection	接管樣式 Connection	作動形式 Actuation
	AL : 氣動 (Pneumatic)	T : PTFE	1 : FKM 2 : EPDM 3 : FFKM	12 : 1-1/2" ( $\varnothing 38.1 \times \varnothing 33.7$ )	5 : Sleeve Insertion 入珠式	C : 常閉 (Normally Close)

## 註

1. 驅動部材質使用規範，請參考 P.附3 「關於驅動部材質使用規範」。

## 外型尺寸圖 Exterior Structure

## ● 氣動閥

